

Hydraulic Excavators

XE155U



Rated Power: 121 hp
Operating Weight: 35,031 lb
Bucket Capacity: 0.85 yd³

XCMG North America Corporation
5145 Schirlls Street, Las Vegas, NV 89118
Email: info@xcmgusa.com
Phone: (Las Vegas) 725-605-2777
(Houston) 346-409-2855
Web: www.xcmg-usa.com





Technical Specifications

Engine

Designed to deliver superior performance and fuel efficiency, the Cummins T4F diesel engine fully meets the emissions regulations. To optimize machine performance, the engine uses high-pressure fuel injectors, VGT™ turbocharger inter-cooler and electronic engine controls. 4-Cycle Water-Cooled, turbocharged, Exhaust Gas Recirculation (EGR) and Selective Catalytic Reduction (SCR) with a Diesel Particulate Filter (DPF).

Model	Cummins B4.5
No. of cylinders	4
Rated power at 2100 rpm	
(SAE J1995)	121 hp at 2200rpm
(SAE J1349)	—
(ISO 9249)	—
Max. torque at 1500 rpm	369 lb.ft
Idle (low - high)	950-1100 rpm
Piston displacement	1.2 gal
Bore × stroke	4" × 5"
Starter	24 V × 6.4 hp
Batteries - Alternator	2 × 12 V, 95 Ah - 24 V, 70 A
Air filter	Donaldson the latest PSD air filter and pre-filtered dust separator

Weight

	Shoe width (in.)	Operating weight (lb)	Ground pressure (psi)
Triple grouser	24"	35,031	5.9
	20"	34,833	7.1
	28"	35,230	5.1
	31"	35,428	4.5

Hydraulic system

The XICS (XCMG Intelligent Control System) is the brain of the excavator, which minimizes the fuel consumption and enables the hydraulic system optimized and efficient for all working conditions. To harmonize the operation of the engine and the hydraulics, the XICS is connected to the engine's electronic control unit (ECU) via a data transfer link.

- The hydraulic system enables independent or combined operations - 2 travel speeds offer either increased torque or high speed
- 8 work modes, 3 power modes - Flow and pressure control of auxiliary hydraulic circuits from control panel
- Computer-aided pump flow control

> Pumps flow & system pressure

Main pumps, type:	2 × variable displacement tandem axial piston pumps
Maximum flow at 1800 rpm	2×31 gal/min
Pilot pump, type:	Gear pump
Maximum flow at 1800 rpm	4.8 gal/min
Relief valve settings:	
Pressure up	4,978/5,405 psi
Travel	4,978 psi
Swing	3,627 psi
Pilot	569 psi

Undercarriage

Extremely robust construction throughout - made of high-quality, durable materials, with all welded structures designed to limit stresses.

- Track shoes made of induction-hardened alloy with triple grouser
- Heat-treated connecting pins
- Hydraulic track adjuster with shock-absorbing tension mechanism

> Number of rollers and track shoes per side

Upper rollers (standard shoe)	1
Lower rollers	7
Number of links & shoes per side	45
Overall track length	12'

Cab

The air-conditioning and heating systems are integrated for optimal climate control. An automatically controlled fan supplies the pressurized and filtered cab air, which is distributed throughout the cab from multiple vents. The heated air suspension, adjustable operator's seat includes a seat belt. The operator can adjust the ergonomic seat and joystick console separately according to his preferences.

Note – Declared single-number noise emission values are the sum of measured values and the associated uncertainty, and they represent upper boundaries of the range of values which is likely to occur in measurements.

> Noise emission

Noise level LpA(IOS 6396)	71 dB(A)
Noise level LwA(IOS 6395)	101 dB(A)



Technical Specifications

Component weights

Item	Unit	XE155U	Remarks
Upper structure without front	lb	17,769	With counterweight
Lower structure assembly	lb	11,332	24" shoe shoe
Front assembly	lb	5,732	Without cylinder
Counterweight	lb	6,393	Standard counterweight:
Boom	ft/lb	15'11"/1,975	including bushing
Arm	ft/lb	8'3"/1,008	including bushing
		9'11"/1,188	

Drive

Each track is driven by an independent, high-torque axial piston motor through a planetary reduction gearbox. Two levers / foot pedals guarantee smooth travel with counter-rotation on demand. The track frame protects the travel motor, brake and planetary gears. The multi-disc track brakes are spring-applied and hydraulic released.

> Speed & traction

Travel speed (low - high)	1.9-3 mph
Maximum traction	25,628 lbf
Maximum gradeability	35° / 70%

Buckets

Bucket type	Capacity (yd³) SAE	Width (in.)		Weight (lb)	Boom 15'1"	
		With side cutters	W/o side cutters		Arm 8'3"	Arm 9'11"
					Shoe 24"	Shoe 24"
GP	0.42	24	24	829	A	A
	0.52	35	35	948	A	A
	0.78	43	43	1,105	B	C
	0.92	49	49	1,188	C	-
HD	0.68	40	40	1,096	A	B
	0.72	41	41	1,135	A	B
	0.78	44	44	1,164	B	C
	0.85	46	46	1,186	B	C
SD	0.92	50	50	1,254	C	-
	0.68	37	37	1,131	A	B

Hydraulic cylinders

High-strength steel piston rods and cylinder bodies. Shock-absorbing mechanism fitted in all cylinders for shock-free operation and extended piston life.

Cylinders	Quantity	Bore x rod diameter x stroke (in)
Boom	2	4.1 x 2.8 x 37
Arm	1	4.5 x 3.1 x 44.1
Bucket	1	3.9 x 2.8 x 33.5

Swing mechanism

The swing mechanism uses an axial piston motor, driving a 2-stage planetary reduction gear bathed in oil for maximum torque.

- Swing bearing: single-row, shear type ball bearing with induction hardened internal gear
- Internal gear and pinion immersed in lubricant

> Swing speed & torque

Maximum swing speed	11.5 rpm
Maximum swing torque	28,027 ft·lb

> Fluid capacities

Fuel tank	66 gal
Cooling system (radiator)	5.5 gal
Urea (def) tank	6.6 gal
Hydraulic oil tank	25.1 gal
Engine oil	2.9 gal
Swing drive	0.5 gal
Travel device	2x0.6 gal

GP: General purpose; HD: Heavy duty; SD: Severe duty;

A: Suitable for materials with a density less than or equal to 2100 kg/m³ (131.1 lb/ft³)

B: Suitable for materials with a density less than or equal to 1800 kg/m³ (112.37 lb/ft³)











C: Suitable for materials with a density less than or equal to 1500 kg/m³ (93.64 lb/ft³)



Based on ISO 10567 and SAE J296, arm length without quick-coupler. For reference only.

Lifting Capacities

XE155U

Standard track width: 8'6" · W/O Bucket(lb)

Lph (ft)	Lpr (ft)	4.9 ft		9.8 ft		14.8 ft		19.7 ft		Max. reach		A(mm/ft)
	B											
One-piece boom 15'1" Arm 8'3" Shoe /24" Counterweight 6,395 lb	19.7					*7,194	7,647			*6,769	5,667	17'7"
	14.8					*7,642	7,446	7,215	4,752	6,566	4,317	20'10"
	9.8			*12,236	12,937	*9,384	7,069	7,082	4,631	5,729	3,744	22'6"
	4.9			*11,193	11,607	10,555	6,604	6,873	4,439	5,537	3,621	23'1"
	Floor			*16,987	10,992	10,161	6,260	6,692	4,275	5,535	3,568	22'7"
	-4.9	*12,317	*12,318	20,081	11,010	10,057	6,172	6,672	4,258	6,139	3,929	20'10"
	-9.8	*21,737	*21,737	*16,144	11,071	10,077	6,187			7,832	4,950	17'7"

 : Over front
 : Over side or 360°

1. The lifting capacity ratings are based on ISO10567.
2. * The maximum lifting capacity is limited by hydraulic rather than tipping load.
3. With the machine standing on level and firm ground, the lifting capacity does not exceed 87% of the hydraulic capacity or 75% of the tipping load.
4. The operator should be familiar with the machinery operation and maintenance manuals. Local regulations concerning the operation safety of machinery must be followed at all times.
5. The lift diagrams only cover machines that are originally built by the XCMG: without lifting chains and any other lifting equipment.
6. When the excavator is used to lift or handle materials, it must comply with local regulations.



Technical Specifications

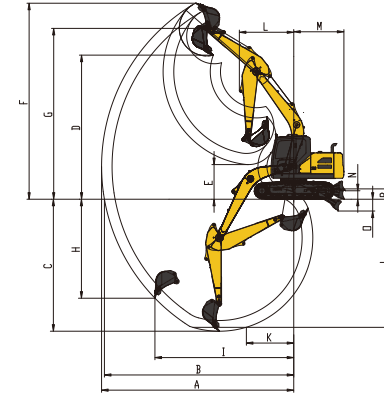
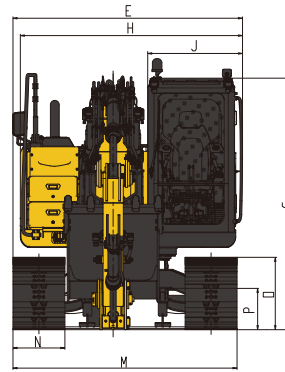
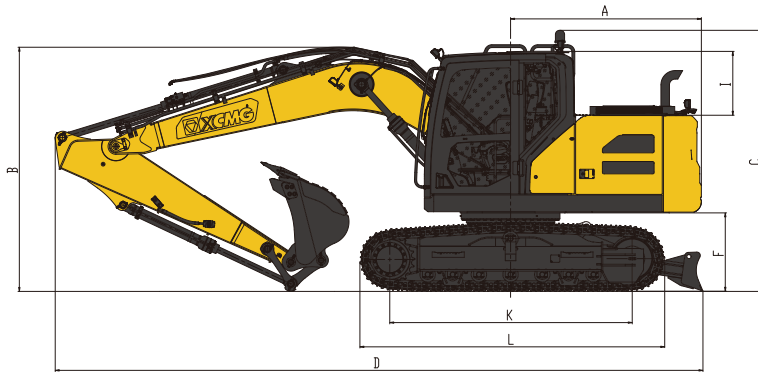

Dimensions

XE155U		ft	
Boom length - ft		15'1"	
Arm length - ft		8'3"	9'11"
Bucket capacity - yd ³		0.85	0.85
A	Tail swing radius	7'6"	7'6"
B	Shipping height (boom)	9'7"	9'8"
C	Shipping height (Cab)	10'3"	10'3"
D	Shipping length	25'6"	25'7"
E	Shipping width	8'8"	8'8"
F	Counterweight clearance	37"	37"
G	Height over cab	9'6"	9'6"
H	House width	8'5"	8'5"
I	Cab height above house	30"	30"
J	Cab width	3'7"	3'7"
K	Tumbler distance	9'7"	9'7"
L	Track length	12'	12'
M	Undercarriage width	8'6"	8'6"
N	Shoe width std.	24"	24"
O	Track height	33"	33"
P	Ground clearance	19"	19"

Digging forces (ISO)

XE155U		ft	
Boom length - ft		15'1"	
Arm length - ft		8'3"	9'11"
Bucket capacity - yd ³		0.85	0.85
Bucket(Normal/Press. Up) - lbf		22,256/24,055	22,256/23,830
Arm(Normal/Press. Up) - lb		15,961/17,085	13,938/15,062

Working range

XE155U		ft	
Boom length - ft		15'1"	
Arm length - ft		8'3"	9'11"
Bucket capacity - yd ³		0.85	0.85
A	Max. digging reach	27'2"	28'9"
B	Max. digging reach (ground)	26'9"	28'4"
C	Max. digging depth	18'2"	19'9"
D	Max. loading height	20'4"	21'7"
E	Min. loading height	6'10"	6'10"
F	Max. digging height	28'4"	29'4"
G	Max. bucket pin height	24'5"	25'7"
H	Max. vertical wall depth	15'	14'10"
I	Max. radius vertical	18'4"	20'9"
J	Max. digging depth (8' level)	17'4"	19'2"
K	Min. radius 8' line	7'2"	7'1"
L	L Min. swing radius	8'1"	8'2"
M	Real swing radius	7'6"	7'6"
N	Max. Blade height	15"	15"
O	Max. Blade depth	21"	21"
P	Blade height	23"	23"